

令和元年度 秋季募集
(令和 2 年 4 月入学)
東北大学大学院量子エネルギー工学専攻入学試験
試験問題冊子

数学 A MATHEMATICS A

令和元年 8 月 27 日(火)

Tuesday, August 27, 2019 9:30 – 11:00

Notice

1. Do not open this test booklet until instructed to do so.
2. A test booklet, answer sheets, draft sheets are provided. Put your examinee number on each of the answer sheets, the draft sheets, and the form.
3. Answer all problems. Use two answer sheets for each problem.
4. At the end of the examination, double-check your examinee number and the problem numbers on the answer sheets. Put your answer sheets in numerical order on top of the other sheets, place them beside the test booklet, and wait for collection by an examiner. Do not leave your seat before instructed to do so by the examiner.

数学 A MATHEMATICS A

1. Solve the following problems.

(1) Evaluate the indefinite integral

$$\int \frac{2x}{x^4 + x^2 + 1} dx.$$

(2) Evaluate the definite integral

$$\int_1^3 \frac{x^2}{x^2 - 4x + 5} dx.$$

(3) Evaluate the infinite integral

$$\int_0^{\infty} \frac{x^2}{(x^2 + 2x + 2)^2} dx.$$

2. The 3×3 matrix A is given by

$$A = \begin{pmatrix} 2 & -1 & 0 \\ -1 & 3 & -1 \\ 0 & -1 & 2 \end{pmatrix}.$$

Solve the following problems.

- (1) Find the inverse matrix of A .
- (2) Find the eigenvalues and eigenvectors of A .
- (3) Find coefficients a , b , and c such that $A^3 + aA^2 + bA + cI = O$, where I and O are the identity matrix and the zero matrix, respectively.
- (4) Obtain $A^4 - 6A^3 + 7A^2 - 8A + 2I$.

3. In the Cartesian coordinate system (x, y, z) , the vector field \mathbf{A} is given by

$$\mathbf{A} = \frac{x}{\sqrt{x^2 + y^2}} \mathbf{i} + \frac{y}{\sqrt{x^2 + y^2}} \mathbf{j} + \frac{z}{\sqrt{x^2 + y^2}} \mathbf{k},$$

where \mathbf{i} , \mathbf{j} , and \mathbf{k} are the fundamental vectors in the x , y , and z directions, respectively. Let S be the surface of the region V given by

$$V = \{ (x, y, z) \mid a^2 \leq x^2 + y^2 \leq b^2, \ 0 \leq z \leq c \},$$

where a , b , and c are real numbers satisfying $0 < a < b$ and $c > 0$. Solve the following problems.

(1) Obtain $\nabla \cdot \mathbf{A}$.

(2) Obtain $\nabla \times \mathbf{A}$.

Introduce the cylindrical coordinate system (r, θ, z) as shown in Fig. 1 and let \mathbf{e}_r , \mathbf{e}_θ , and \mathbf{e}_z be the fundamental vectors in the r , θ , and z directions, respectively. Solve the following problems.

(3) Represent \mathbf{i} and \mathbf{j} in the cylindrical coordinate system.

(4) Represent \mathbf{A} in the cylindrical coordinate system.

(5) Evaluate the integral

$$\int_S \mathbf{A} \cdot \mathbf{n} \, dS,$$

where \mathbf{n} is the outward unit normal vector of S .

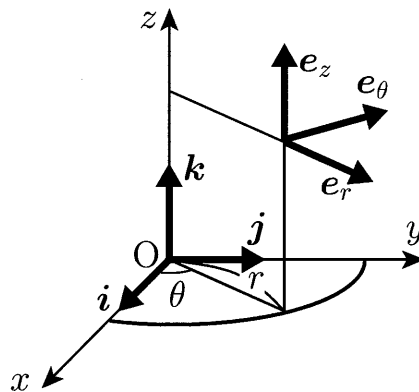

Fig. 1

令和元年度 秋季募集
(令和 2 年 4 月入学)
東北大学大学院量子エネルギー工学専攻入学試験

試験問題冊子

数学B MATHEMATICS B

令和元年 8 月 27 日(火)

Tuesday, August 27, 2019 13:30 – 15:00

Notice

1. Do not open this test booklet until instructed to do so.
2. A test booklet, answer sheets, draft sheets are provided. Put your examinee number on each of the answer sheets, the draft sheets, and the form.
3. Answer all problems. Use two answer sheets for each problem.
4. At the end of the examination, double-check your examinee number and the problem numbers on the answer sheets. Put your answer sheets in numerical order on top of the other sheets, place them beside the test booklet, and wait for collection by an examiner. Do not leave your seat before instructed to do so by the examiner.

数学 B MATHEMATICS B

1. Find the general solutions of the following ordinary differential equations.

$$(1) \frac{dy}{dx} = (y - 4x + 1)^2$$

$$(2) \frac{d^2y}{dx^2} - 4\frac{dy}{dx} + 5y = \sin x$$

$$(3) x^2 \frac{d^2y}{dx^2} - 3x \frac{dy}{dx} + 4y = \log x \quad (x > 0)$$

2. The Fourier transform $F(\omega)$ of a function $f(x)$ and its inverse transform are defined by

$$F(\omega) = \int_{-\infty}^{\infty} f(x) e^{-i\omega x} dx,$$

$$f(x) = \frac{1}{2\pi} \int_{-\infty}^{\infty} F(\omega) e^{i\omega x} d\omega.$$

Solve the following problems.

(1) Obtain the Fourier transform $F(\omega)$ of the following function

$$f(x) = \begin{cases} -x & (0 < x \leq 1) \\ x - 2 & (1 < x \leq 2) \\ 0 & (x \leq 0, x > 2). \end{cases}$$

(2) Obtain $|F(\omega)|^2$ using $F(\omega)$ obtained in problem (1).

(3) Evaluate $\int_0^{\infty} \frac{(\cos x - 1)^2}{x^4} dx$ using $\frac{1}{2\pi} \int_{-\infty}^{\infty} |F(\omega)|^2 d\omega = \int_{-\infty}^{\infty} \{f(x)\}^2 dx$.

3. The Laplace transform of a function $f(t)$ is defined by

$$\mathcal{L}[f(t)] = F(s) = \int_0^{\infty} f(t) e^{-st} dt.$$

Solve the following problems.

(1) Derive

$$\mathcal{L}\left[\frac{f(t)}{t}\right] = \int_s^{\infty} F(s') ds',$$

when $f(t)$ satisfies that $\lim_{s \rightarrow \infty} \int_0^{\infty} \frac{f(t)}{t} e^{-st} dt = 0$.

(2) Obtain the Laplace transform of $\sin^2 t$.

(3) Obtain the Laplace transform of $\frac{\sin^2 t}{t}$.

(4) Evaluate $\int_0^{\infty} \frac{e^{-2t} \sin^2 t}{t} dt$.

令和元年度 秋季募集
(令和2年4月入学)
東北大学大学院量子エネルギー工学専攻入学試験

試験問題冊子
【専門科目 Specialized Subjects】

熱力学	THERMODYNAMICS	P1~P2
流体力学	FLUID DYNAMICS	P3~P4
材料力学	STRENGTH OF MATERIALS	P5~P6
機械力学	DYNAMICS OF MECHANICAL SYSTEMS	P7~P8
制御工学	CONTROL ENGINEERING	P9~P10
材料物性学	MATERIALS SCIENCE	P11~P12
電磁気学	ELECTROMAGNETICS	P13~P14
量子力学	QUANTUM MECHANICS	P15~P16

令和元年 8月28日 (水) 9:00 – 12:00
Wednesday, August 28, 2019 9:00 – 12:00

Notice

1. Do not open this test booklet until instructed to do so.
2. A test booklet, answer sheets, draft sheets, and two selected-subjects forms are provided. Put your examinee number on each of the answer sheets, the draft sheets, and the form.
3. Select two subjects from the eight subjects in the booklet and answer all problems in each subject. Indicate your selection on the selected-subjects form. Use one set of two answer sheets for each subject, and use one sheet per problem.
4. At the end of the examination, double-check your examinee number and the problem numbers on the answer sheets. Put your answer sheets in numerical order on top of the other sheets, place them beside the test booklet, and wait for collection by an examiner. Do not leave your seat before instructed to do so by the examiner.

熱力学 THERMODYNAMICS

1. Figure 1 shows gas-liquid equilibrium lines (evaporation curves) including both end points of pure substances A and B plotted on a $\ln p - \frac{1}{T}$ diagram. Here, p and T denote pressure and temperature, respectively, and \ln represents natural logarithm. Answer the following questions.

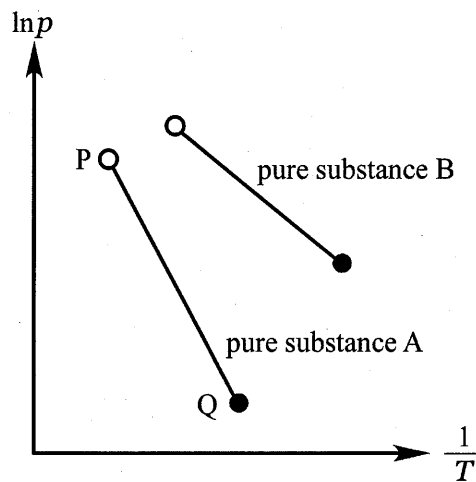

Fig. 1

- (1) Describe the names of end points P and Q.
- (2) When the pressure and temperature change with keeping the state of gas-liquid equilibrium, show that the following equation is satisfied. Here, specific entropy and specific volume of the gas phase are denoted by s_G and v_G , respectively, and those of the liquid phase are denoted by s_L and v_L , respectively.

$$\frac{dp}{dT} = \frac{s_G - s_L}{v_G - v_L}$$

- (3) Express $\frac{dp}{dT}$ in question (2) using v_G , v_L , T and r , where r is the latent heat of vaporization per unit mass.
- (4) When the molecular weights of pure substances A and B are equal, show which pure substance has the larger latent heat of evaporation per unit mass, and describe its reason. Assume that the specific volumes of the gas phases are sufficiently large compared with those of liquid phases, and that the gas phases obey the equation of state of an ideal gas. Also, the latent heats of vaporization per unit mass are assumed to be constant.

2. Consider a cycle for an ideal gas in a closed system. The cycle consists of three quasi-steady processes, which are an adiabatic compression process of state $1 \rightarrow 2$, an isobaric heating process of state $2 \rightarrow 3$ and an isochoric cooling process of state $3 \rightarrow 1$. The temperature and specific entropy at state 1 are T_1 and s_1 , respectively. The temperature at state 2 is T_2 . The temperature and specific entropy at state 3 are T_3 and s_3 , respectively. The specific heat ratio and the gas constant of the ideal gas are κ and R , respectively. Answer the following questions.
- (1) Show the specific heat at constant volume and that at constant pressure of the gas using κ and R .
 - (2) Draw the temperature–specific entropy (T – s) diagram of the cycle.
 - (3) Show the change of specific entropy, $s_1 - s_3$, during the process of state $3 \rightarrow 1$ using T_1 , T_3 , κ and R .
 - (4) Show the temperature at state 3, T_3 , using T_1 , T_2 and κ .
 - (5) Show the thermal efficiency of the cycle using ε and κ , where ε is the compression ratio during the process of state $1 \rightarrow 2$.

1. Consider a two-dimensional steady potential flow of an inviscid incompressible fluid. The complex potential $W(z)$ of the flow is given by

$$W(z) = Uz - m \log z,$$

where U and m are positive real numbers, and \log is the natural logarithm. The complex variable z is given by $z = x + iy = re^{i\theta}$, where x and y are the Cartesian coordinates, r and θ are the radial and circumferential coordinates, respectively, and $i = \sqrt{-1}$. Answer the following questions.

- (1) Obtain the velocity potential $\Phi(r, \theta)$ and the stream function $\Psi(r, \theta)$ of the flow field.
- (2) Obtain the coordinates of a stagnation point in the flow field.
- (3) Obtain the coordinates of the points at which the streamlines through the stagnation point cross the y axis.
- (4) Draw streamlines with their directions in the flow field.
- (5) Obtain the stagnation pressure, and draw the pressure profile along the x axis, assuming that the pressure far upstream is p_∞ and the density of the fluid is constant at ρ .

2. Consider coaxial cylinders centered at the origin O , as shown in Fig. 1. The inner cylinder with the radius a is stationary. The outer cylinder with the radius b is rotating at the constant angular velocity Ω . A steady two-dimensional circumferential flow of an incompressible viscous fluid is induced between the two cylinders. Assuming that external forces are negligible, the density ρ and the viscosity μ of the fluid are constant, answer the following questions.

(1) In the cylindrical coordinate (r, θ) shown in Fig. 1, the radial component of the steady Navier–Stokes equations is expressed as

$$u_r \frac{\partial u_r}{\partial r} + \frac{u_\theta}{r} \frac{\partial u_r}{\partial \theta} - \frac{u_\theta^2}{r} = -\frac{1}{\rho} \frac{\partial p}{\partial r} + \frac{\mu}{\rho} \left(\frac{\partial^2 u_r}{\partial r^2} + \frac{1}{r} \frac{\partial u_r}{\partial r} + \frac{1}{r^2} \frac{\partial^2 u_r}{\partial \theta^2} - \frac{2}{r^2} \frac{\partial u_\theta}{\partial \theta} - \frac{u_r}{r^2} \right)$$

and the circumferential component is expressed as

$$u_r \frac{\partial u_\theta}{\partial r} + \frac{u_\theta}{r} \frac{\partial u_\theta}{\partial \theta} + \frac{u_r u_\theta}{r} = -\frac{1}{\rho r} \frac{\partial p}{\partial \theta} + \frac{\mu}{\rho} \left(\frac{\partial^2 u_\theta}{\partial r^2} + \frac{1}{r} \frac{\partial u_\theta}{\partial r} + \frac{1}{r^2} \frac{\partial^2 u_\theta}{\partial \theta^2} + \frac{2}{r^2} \frac{\partial u_r}{\partial \theta} - \frac{u_\theta}{r^2} \right).$$

Here, p , u_r and u_θ are the pressure, the radial component of the velocity and the circumferential component of the velocity, respectively. Assuming that u_r is zero and that u_θ and p are functions of r alone, answer the following questions.

- a) Obtain the relation among r , ρ , p and u_θ using the equation for the radial component.
 - b) Obtain the relation between u_θ and r using the equation for the circumferential component.
- (2) The equation obtained in a) of question (1) indicates that pressure gradient is generated when $u_\theta \neq 0$. Explain the reason of the pressure gradient briefly.
 - (3) Express u_θ using a , b , Ω and r with the aid of the equation obtained in b) of question (1). Here, particular solutions of the equation have a form of $u_\theta = Cr^k$, where C and k are constants.
 - (4) Express the shear stress τ exerted on the surface of the inner cylinder using a , b , Ω and μ .
 - (5) Express the torque T per unit axial length acting on the surface of the inner cylinder using a , b , Ω and μ .

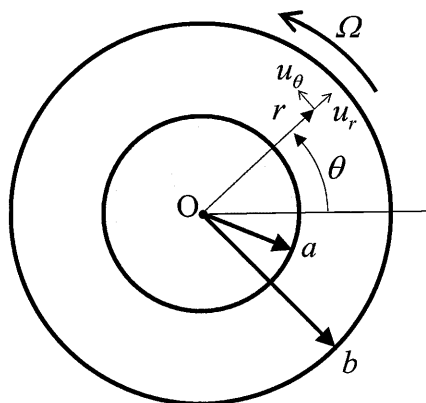

Fig. 1

1. Consider a stepped solid circular shaft ABC as shown in Fig. 1. The diameter and length of portion AB are $2d$ and L , and those of portion BC are d and L , respectively. The shaft is fixed at left end A to a vertical rigid wall. The shear modulus of the shaft is G . Answer the following questions.

- (1) As shown in Fig. 1(a), the shaft is twisted by the twisting moment M_{t1} at position B and the twisting moment M_{t2} at right end C. Here the twisting direction of M_{t2} is reverse to that of M_{t1} . Find the twisting angle ϕ_c at right end C.
- (2) Determine the maximum shear stress and indicate its location in question (1).
- (3) As shown in Fig. 1(b), two bars are pin-connected to the shaft surface at two intersection points D and F where a horizontal line passing through the center of the axis cuts the outer circumference of right end C. The length, cross sectional area and Young's modulus of the two bars are h , S and E , respectively. The lower ends of the bars are perpendicularly pin-connected to a rigid horizontal floor. The shaft is twisted by the twisting moment M_t at position B. Find the reactive twisting moment M_c and the twisting angle ϕ_c at right end C.

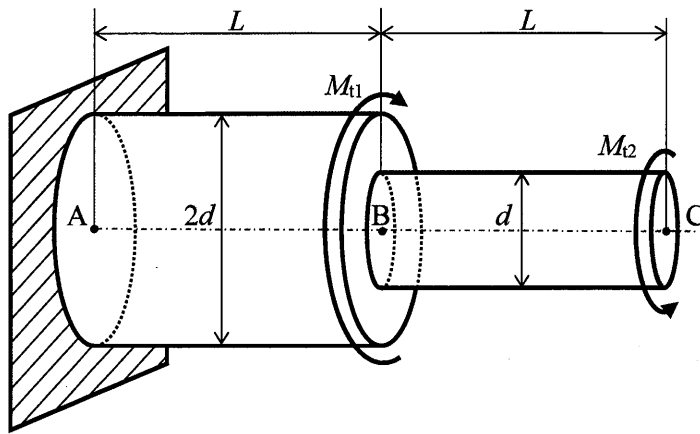

Fig. 1(a)

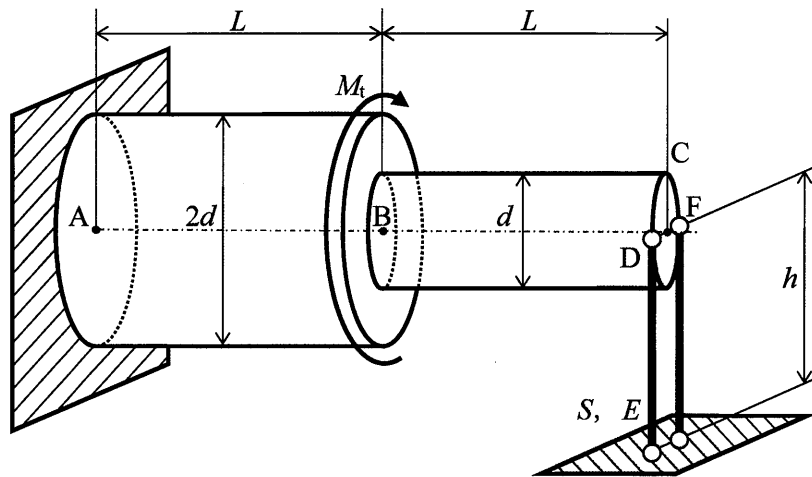

Fig. 1(b)

材 料 力 学 STRENGTH OF MATERIALS

2. As shown in Fig. 2(a), top view, consider beams A_1B_1 , A_2B_2 and CD which are fixed to vertical rigid walls at ends A_1 , A_2 and D , respectively, and have holes at ends B_1 , B_2 and C . As shown in Fig. 2(b), side view, the difference in the height between the neutral axis of beams A_1B_1 and A_2B_2 and that of beam CD is d , where $d \ll L$. The length of beams A_1B_1 and A_2B_2 is $2L$, the length of beam CD is L , and flexural rigidity EI of beams A_1B_1 , A_2B_2 and CD is constant. A vertical load is applied to beam CD at end C until the centers of all the holes are aligned on a straight line, and then, a pin is inserted through the holes. When the load is released, beams A_1B_1 , A_2B_2 and CD are deflected to an equilibrium state. Assume that the diameters of the pin and the holes are identical, and the deformations and friction of the pin and the holes are negligible. Neglect both the weight of the beams and the elongation of the neutral axis of the beams. Answer the following questions.

- (1) Determine the deflection of the beams, δ , at ends B_1 and B_2 .
- (2) Determine the deflection angle of beam A_1B_1 , ϕ_{B_1} , at end B_1 and that of beam CD , ϕ_C , at end C , respectively.
- (3) Determine the reaction force of the beam, R_D , at end D .
- (4) Determine the reaction moment of the beam, M_D , at end D .

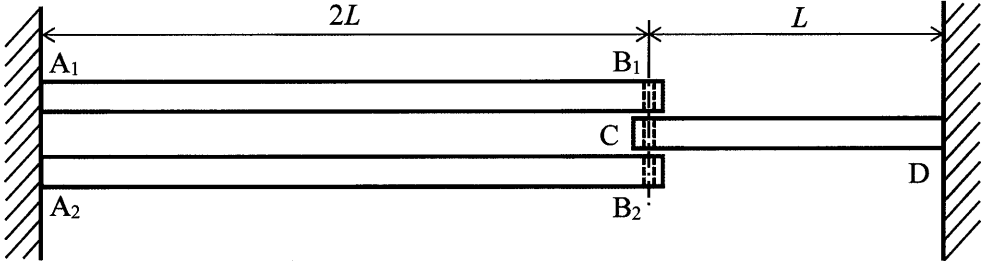

Fig. 2(a) Top view

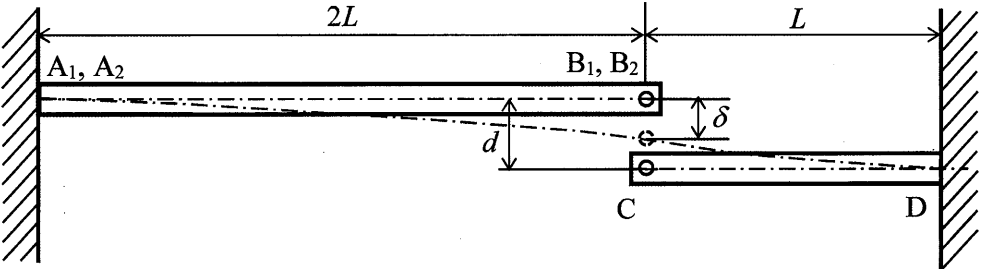

Fig. 2(b) Side view

1. Consider a system consisting of a uniform rigid bar with mass m and length $a + b$, two springs with spring constants k and $2k$, and a dashpot with damping coefficient c , as shown in Fig. 1. The bar is pinned at point O , and rotationally vibrates with sufficiently small displacement around equilibrium position in the plane of the figure. The angular displacement of the rigid bar from the equilibrium position is denoted by $\theta(t)$, where t is time. The dashpot is connected to a ceiling and the ceiling is subjected to vertical displacement excitation $u(t) = A \sin \omega t$, where A and ω are the amplitude and the angular frequency of the displacement, respectively. Assume that the masses of the springs and the dashpot are negligible. When the system is in the steady-state, answer the following questions.
- (1) Obtain the moment of inertia J of the bar about point O .
 - (2) Derive the equation of motion of the system.
 - (3) When $c = 0$, $a = 2\ell$, $b = \ell$, find the natural angular frequency of the system.
 - (4) When $c \neq 0$, $a = 2\ell$, $b = \ell$, find the angular displacement $\theta(t)$.

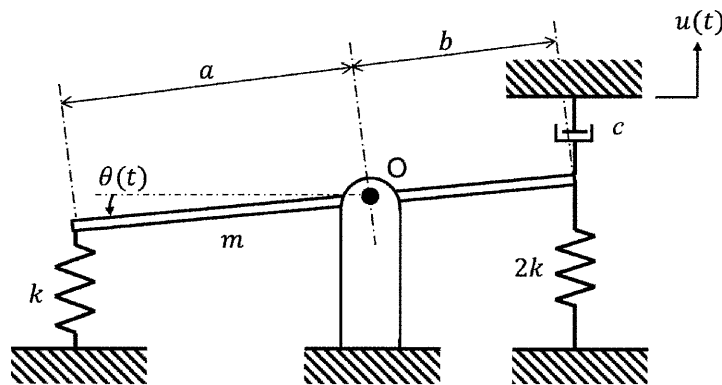

Fig. 1

2. Consider a system consisting of two pulleys with radius r_1 , r_2 and mass moments of inertia J_1 , J_2 , and three springs with spring constants k_1 , k_2 and k_3 , as shown in Fig. 2. The axes of two pulleys are fixed and the three springs are connected by ropes. The ropes do not loosen and there is no slip between the ropes and the pulleys. The masses of the ropes and the springs are negligible. The angular displacements of the pulleys from the equilibrium positions are denoted by θ_1 and θ_2 . Answer the following questions.

- (1) Derive the equations of motion of the system.
- (2) Derive the frequency equation of the system.
- (3) When $J_1 = J$, $J_2 = 4J$, $r_1 = r$, $r_2 = 2r$, and $k_1 = k_2 = k_3 = k$, find the natural angular frequencies of the system.
- (4) Find the amplitude ratio of θ_2 to θ_1 at each natural angular frequency obtained in question (3).

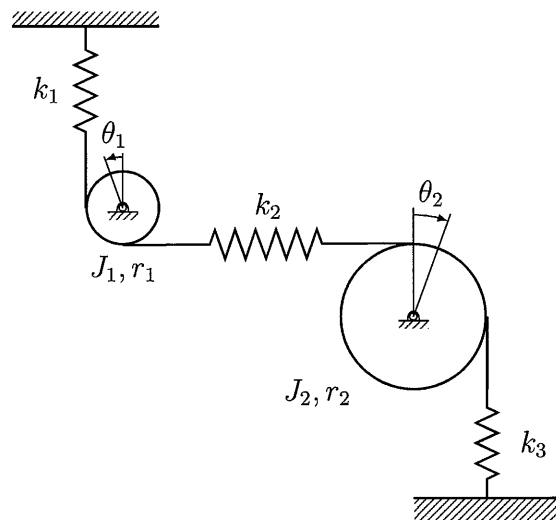

Fig. 2

制御工学 CONTROL ENGINEERING

1. Solve the following problems.

(1) Find the impulse response of the transfer function

$$G(s) = \frac{7s + 15}{s(s + 3)(s + 5)}.$$

(2) Consider the control system shown in Fig. 1.

- a) Find the range of k for the system to be stable.
- b) Draw the root loci of the system.
- c) Calculate the gain margin when $k = 16$.

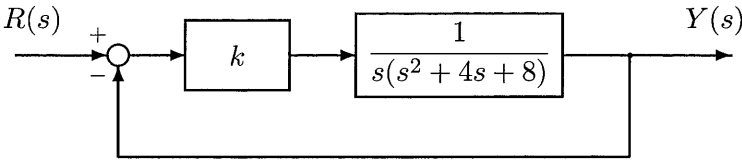

Fig. 1

(3) When the vector locus of the frequency transfer function $G(j\omega)$ is given in Fig. 2, find the output for the input $\sin(\omega_0 t)$.

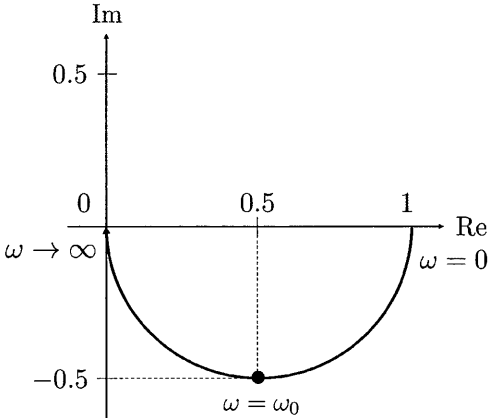

Fig. 2

(4) Consider the system given in Fig. 3. When the disturbance is $d(t) = t$ and the input is $r(t) = 0$, determine the range of k for the steady-state output to be $|y(\infty)| < 0.5$.

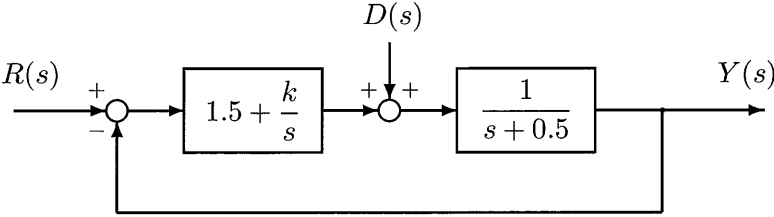

Fig. 3

2. Solve the following problems.

(1) Consider the system

$$\dot{\mathbf{x}}(t) = \mathbf{A}\mathbf{x}(t) + \mathbf{b}u(t), \quad y(t) = \mathbf{c}\mathbf{x}(t),$$

where $u(t)$ is the input, $y(t)$ is the output, and $\mathbf{x}(t) = [x_1, x_2]^T$ is the state vector. When

$$\mathbf{A} = \begin{bmatrix} 0 & 1 \\ 3 & 2 \end{bmatrix}, \quad \mathbf{b} = \begin{bmatrix} 0 \\ 1 \end{bmatrix}, \quad \mathbf{c} = [1, 2],$$

determine the range of $\mathbf{k} = [k_1, k_2]$ for the closed-loop system to be stable under the state feedback $u(t) = -\mathbf{k}\mathbf{x}(t)$.

(2) Suppose $\mathbf{k} = [9, 7]$ in problem (1). Find the coordinate transformation $\mathbf{x}(t) = \mathbf{T}\mathbf{z}(t)$ to diagonalize the closed-loop system, and find the diagonalized system $\dot{\mathbf{z}}(t) = \mathbf{M}\mathbf{z}(t)$.

(3) Consider the system

$$\dot{\mathbf{z}}(t) = \mathbf{F}\mathbf{z}(t) + \mathbf{g}v(t), \quad y(t) = \mathbf{h}\mathbf{z}(t),$$

where $v(t)$ is the input, $y(t)$ is the output, and $\mathbf{z}(t) = [z_1, z_2]^T$ is the state vector. When

$$\mathbf{F} = \begin{bmatrix} -1 & 0 \\ 0 & -2 \end{bmatrix}, \quad \mathbf{g} = \begin{bmatrix} 1 \\ -1 \end{bmatrix}, \quad \mathbf{h} = [-1, -3],$$

and the initial state $\mathbf{z}(0) = [0, 0]^T$, obtain the response for the unit step input.

(4) For the system in problem (3), consider the error integral feedback $v(t) = \lambda\xi(t)$ as shown in Fig. 4, where λ is a constant gain, $r(t)$ is the input, and $y(t)$ is the output.

- a) Derive the state equation of the augmented system with the state vector as $[z_1, z_2, \xi]^T$.
- b) Find the range of λ for the system to be stable.
- c) Evaluate the steady-state error $e(\infty)$ for the unit step input.

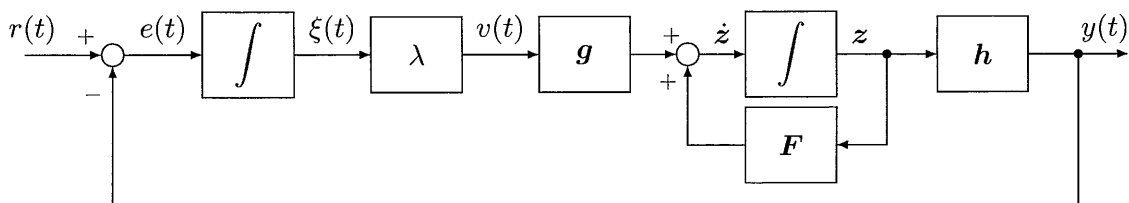

Fig. 4

1. Consider fracture of materials. Answer the following questions.

- (1) Draw typical tensile stress-strain curves of aluminum and alumina at ambient temperature. No need to give specific values of stress and strain. Explain the difference between the fracture modes in terms of the stress-strain curves.
- (2) Explain the formation process of the cup-and-cone type fracture surface with schematic illustrations.
- (3) Obtain a stress intensity factor K_I in an infinite plate with a crack length of 6.4 mm under a uniform remote stress of 100 MPa perpendicular to the crack as shown in Fig. 1. Round off a decimal.
- (4) Assuming that a crack with a length of $2a$ extends Δa to the right and left as shown in Fig. 2, a change of the surface energy per unit thickness $\Delta\Gamma$ is expressed by

$$\Delta\Gamma = 4\gamma\Delta a \quad ,$$

where γ is surface energy per area. In addition, when a crack extends Δa to the right and left, a change in the potential energy per unit thickness ΔU can be expressed by elasticity theory, i.e.,

$$\Delta U = -\frac{2\pi\sigma^2 a}{E} \Delta a \quad ,$$

where E is Young's modulus. Based on these relationships between crack extension and energy variation, show an equation of a critical stress for crack extension. Here, effects of energy consumed for plastic deformation are ignored.

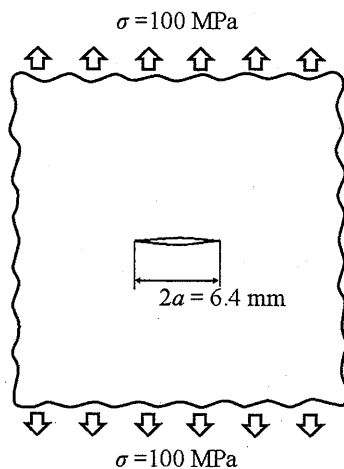

Fig. 1

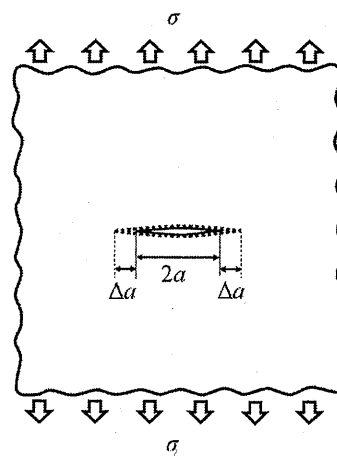

Fig. 2

2. Answer the following questions about diffusion in solids.

- (1) Select two sentences from (i) to (v) in which the content is incorrect as a general explanation. For each, point out the incorrect part(s) and describe the reason(s) you choose.
- (i) The diffusion coefficient of migrating atoms in a solid can be written as a function of intrinsic frequency factor, activation energy of diffusion, and temperature. Then, the diffusion flux is proportional to the coefficient.
 - (ii) In iron, substitutional solute atoms have a greater diffusion coefficient than interstitial solute atoms. Therefore, the substitutional solute atoms can migrate at lower temperatures.
 - (iii) In irradiated metals in which a large number of lattice defects were introduced by neutron bombardments in a nuclear reactor, the self-diffusion coefficient is larger than before the irradiation.
 - (iv) The diffusion coefficient is plotted logarithmically with respect to the reciprocal of temperature, and if it can be linearly approximated, the activation energy of diffusion can be estimated from the slope and the gas constant.
 - (v) In steady state creep of metals, deformation proceeds in constant strain rate due to dislocation motion, suggesting that atomic diffusion in the solid does not contribute to the phenomena.

(2) Consider a system in which the tube is partitioned into two rooms by a metal plate (1.0 mm in thickness) as shown in Fig. 3. The left side of the tube is kept constant at a H_2 partial pressure of 1.0×10^4 Pa and the right side at 1.0×10^2 Pa, respectively. The system is kept constant at $300^\circ C$. The diffusion coefficient of H atoms in the metal can be estimated from the amount of H_2 gas passing through the metal plate per unit time. The area of the metal plate involved in the diffusion of H atoms is 10 mm^2 , and permeation of H atom through the tube wall can be ignored. The number of H atoms estimated from the amount of H_2 gas leaking to lower pressure side is $2.0 \times 10^{16} \text{ atom} \cdot \text{s}^{-1}$ after the diffusion reached a steady state. At this time, answer the following questions. Here, the metal has FCC structure and the lattice constant is 0.40 nm . Equilibrium dissolution concentration of H atoms beneath the metal surface C_H (at%), which contacts to H_2 gas with partial pressure of p_{H_2} (Pa), can be expressed as $C_H = K_s \sqrt{p_{H_2}}$. Note that K_s is the solubility coefficient and is $2.0 \times 10^{-4} \text{ Pa}^{-1/2}$ at $300^\circ C$ for the metal.

- a) Draw the concentration profile of the H atoms in the plate thickness direction.
- b) Calculate the flux of H atoms in the metal plate.
- c) Calculate the diffusion coefficient of H atoms in the metal.

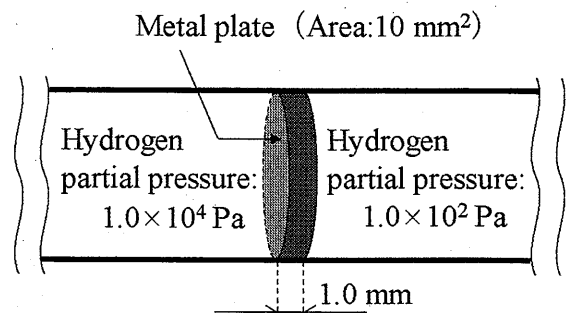

Fig. 3

1. As shown in Fig. 1, there is a sphere A of radius a . Consider two points B and C in alignment with the sphere A so that distances from the center of the sphere are $4l$ and $5l$ ($l > a$), respectively. Use ϵ_0 for the permittivity and answer the following questions.

- (1) Write Gauss's law of electrostatics in integral form.
- (2) A charge Q_A is uniformly distributed inside the sphere A. Find the magnitude of the electric field $E(r)$ and the electric potential $\phi(r)$ as a function of a distance r from the center of the sphere A. Furthermore, plot graphs of $E(r)$ and $\phi(r)$.
- (3) In addition to the condition of question (2), point charges q_B and q_C are placed at the points B and C, respectively. Find the force acting on the point charge q_C .
- (4) In question (3), find conditions so that no force acts on the point charge q_C .

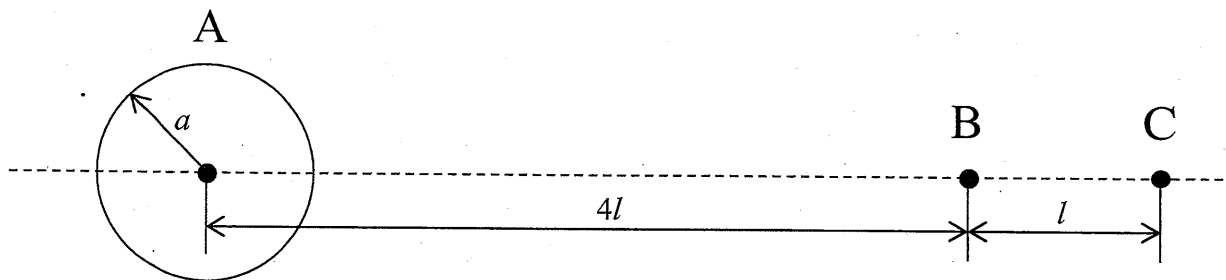

Fig. 1

2. In the cylindrical coordinate system (r, θ, z) , consider a very long solenoid coil with a radius of a and a circular loop of wire C with a radius of b ($b > a$), as shown in Fig. 2. The axis of the solenoid coil coincides with the z -axis, and the solenoid coil uniformly carries θ -direction current per unit z -length, i_θ . The circular loop lies on the $z = 0$ plane with its center at the origin O . Use μ_0 for the permeability. Answer the following questions.

- (1) The magnetic flux density \mathbf{B} outside the solenoid coil ($r > a$) is given by $\mathbf{B} = 0$. Show that \mathbf{B} is uniform inside the solenoid coil ($r < a$), and find the direction and magnitude of \mathbf{B} inside the solenoid coil.
- (2) Find the magnetic flux Φ linked with the loop C .
- (3) Explain the relationship between Φ obtained in question (2) and the magnetic vector potential \mathbf{A} , and find \mathbf{A} inside ($r < a$) and outside ($r > a$) the solenoid coil under the assumption that \mathbf{A} has only θ component.
- (4) Find the induction current I in the loop C , when the current i_θ changes with time t ($0 < t < t_1$) in the form $i_\theta = i_0(1 - t/t_1)$, where i_0 and t_1 are constants. Use R as the resistance of the loop C and neglect magnetic flux density produced by the induction current.

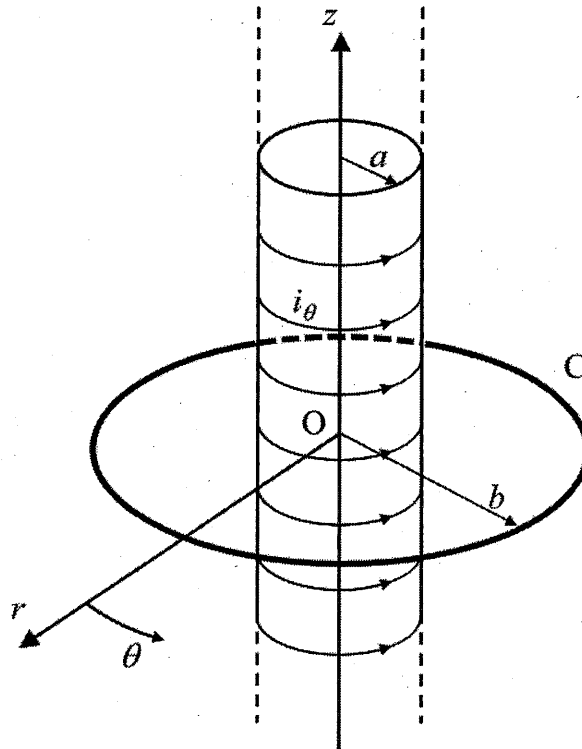

Fig. 2

1. Answer the following questions. Hereafter, Plank's constant is given by h .

- (1) Assume that mass and energy of proton are m_p and E_p , respectively, and those of electron are m_e and E_e , respectively. Here, the relativistic effect in the kinetics can be ignored.
- Show the de Broglie wavelength of the proton using h , m_p and E_p .
 - Find the relationship between E_p and E_e when the proton and the electron have the same de Broglie wavelength.
- (2) Consider a phenomenon that a photon with wavelength λ and momentum p collides with a free electron at rest, and is scattered with wavelength λ' and momentum p' at the angle θ with respect to the incident direction. The relationship between λ and λ' is expressed by $\lambda' - \lambda = [h/(m_0c)](1 - \cos\theta)$, where m_0 is the electron rest mass and c is the speed of light in vacuum.
- Show p' using p , m_0 , c , and θ .
 - Find θ giving the maximum p' . In addition, show the maximum p' .
- (3) A free particle with mass m is enclosed in a certain region. Answer the following questions on the basis of the uncertainty relation between position and momentum. Here, the relativistic effect in the kinetics can be ignored.
- Find the minimum kinetic energy E_a of the free particle enclosed in a region of $-a \leq x \leq a$, $-\infty \leq y \leq \infty$, and $-\infty \leq z \leq \infty$.
 - Find the minimum kinetic energy E_b of the free particle enclosed in a region of $-a \leq x \leq a$, $-a \leq y \leq a$, and $-a \leq z \leq a$.
 - Find the ratio of E_b to E_a , that is (E_b / E_a) in the questions a) and b), and explain the physical meaning of the ratio value.

2. Consider a particle with mass m bound in a potential $V(x)$ in one-dimensional space. The time-independent Schrödinger equation is expressed as follows:

$$-\frac{\hbar^2}{2m} \frac{d^2 \varphi(x)}{dx^2} + V(x) \varphi(x) = E \varphi(x),$$

where E is the eigenvalue of the wave function $\varphi(x)$ and $\hbar \equiv h/(2\pi)$ (h : Planck's constant).

Answer the following questions.

- (1) The expectation value of momentum is given by the following equation:

$$\langle \hat{p} \rangle = \int \varphi^*(x) \hat{p} \varphi(x) dx,$$

where $\varphi(x)$ is a normalized wave function, $\varphi^*(x)$ is the complex conjugate function of $\varphi(x)$, and \hat{p} is the momentum operator.

- a) Explain why the limiting value of $\varphi(x)$ is zero at $x = \pm\infty$.
- b) Write the momentum operator \hat{p} .
- c) Calculate the expectation value of momentum $\langle \hat{p} \rangle$.

- (2) Consider the following potential:

$$V(x) = \begin{cases} +\infty & x < 0 \\ -V_0 & 0 \leq x \leq a \\ 0 & x > a \end{cases} \quad (V_0 > 0)$$

- a) Find the wave functions in the regions of $x > a$ and $0 \leq x \leq a$, when $E > -V_0$.
- b) Find the condition in which two or more stationary states exist.